

Technical Data



KR 200 comp – KR 200 L170 comp –
KR 200 L140 comp



KUKA

WORKING IDEAS

KR 200 comp, KR 200 L170, KR 200 L140

Maße / Dimensions: mm

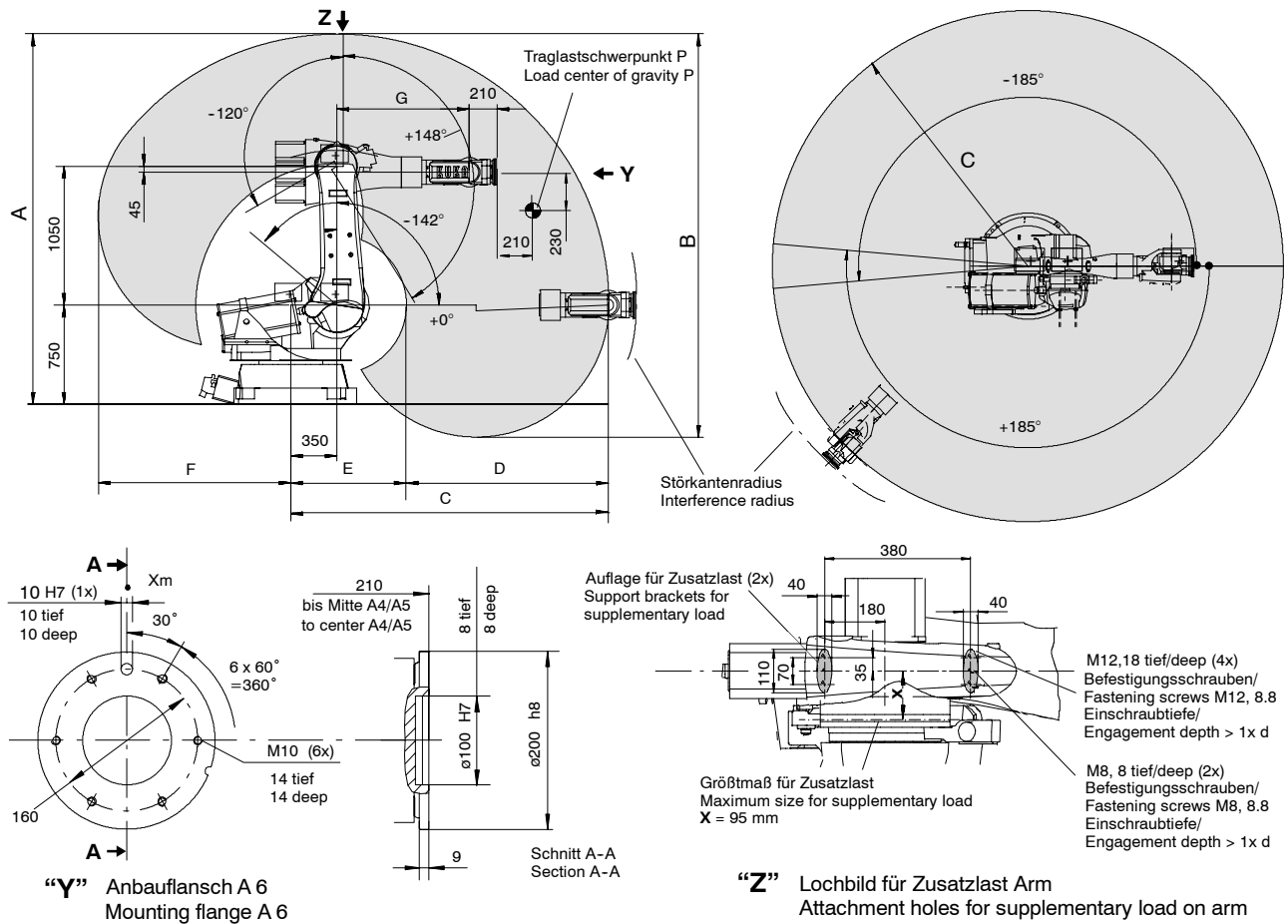

Typ / Type:	KR 200 comp	KR 200 L170 comp	KR 200 L140 comp					
Traglast / Payload:	200 kg	170 kg	140 kg					
Zusatzlast Arm / Schwinge / Karussell Supplementary load on arm / link arm / rotating column:	50/100/300 kg							
Zusatzlast max. Arm und Schwinge Max. supplementary load on arm and link arm:	100 kg							
Max. Gesamtlast / Total distributed load:	600 kg	570 kg	540 kg					
Anzahl der Achsen / Number of axes:	6							
Handvariante / Wrist variant:	Zentralhand 200 kg / In-line wrist 200 kg							
Anbauflansch A 6 / Mounting flange A 6:	DIN ISO 9409-1-A160							
Einbaulage / Mounting position:	Boden / Floor							
Wiederholgenauigkeit / Repeatability:	± 0,15 mm							
Steuerung / Controller:	KR C2							
Gewicht (ohne Steuerung) ca. / Weight (excl. controller) approx.:	1155 kg	1165 kg	1170 kg					
Achsdaten / Axis data:	Bereich (Software) Range (software)	Geschwindigkeit bei Nenntaglast / Speed with rated payload						
		200 kg	170 kg	140 kg				
Achse / Axis 1 (A 1)	± 185°	90 °/s	89 °/s	89 °/s				
Achse / Axis 2 (A 2)	+ 0° / -142°	85 °/s	85 °/s	85 °/s				
Achse / Axis 3 (A 3)	+ 148° / -120°	85 °/s	82 °/s	79 °/s				
Achse / Axis 4 (A 4)	± 350°	117 °/s	117 °/s	117 °/s				
Achse / Axis 5 (A 5)	± 120°	120 °/s	120 °/s	120 °/s				
Achse / Axis 6 (A 6)	± 350°	195 °/s	195 °/s	195 °/s				
Arbeitsraum / Work envelope	Maße / Dimensions ¹⁾							Volumen Volume
	A	B	C	D	E	F	G	
KR 200 comp	2800	3052	2400	1528	873	1455	1000	38,6 m ³
KR 200 L170 comp	3000	3452	2600	1653	948	1655	1200	51,2 m ³
KR 200 L140 comp	3200	3851	2800	1729	1072	1855	1400	66,0 m ³

1) Bezogen auf Schnittpunkt Achse 4/5. / Referred to intersection of axes 4 and 5.

- Antriebssystem elektro-mech. mit bürstenlosen AC-Servomotoren. / Drive system electromechanical, with brushless AC servomotors.
- Wegmeßsystem digital-absolut. / Position sensing system digital-absolute.

Angaben über die Beschaffenheit und Verwendbarkeit der Produkte stellen keine Zusicherungen von Eigenschaften dar, sondern dienen lediglich Informationszwecken. Maßgeblich für den Umfang unserer Lieferungen und Leistungen ist der jeweilige Vertragsgegenstand. Technische Daten und Abbildungen unverbindlich für Lieferung. Änderungen vorbehalten.
Specifications regarding the quality and usability of the products do not constitute a warranty of properties. They are intended to serve informative purposes only. Solely the respective contract of sale shall be binding in respect of the extent of our supplies and services. No liability accepted for errors or omissions.

www.kuka.com